

912 Multi-wire broadband dipole (2 - 30 MHz) - 150 W PEP

27 metres stainless steel, fibreglass spreaders and encapsulated baluns and loads.

Includes:-

- 30 metres of RG-58AU coaxial cable with waterproof UHF coaxial connectors

Note:- Masts illustrated not provided.

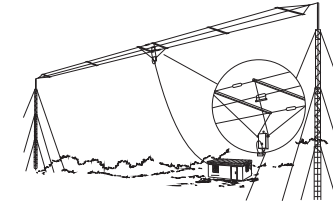

Option for		Part Number	Packaging Type	Net Weight	
2030	2050				
x	x	BC91200	N/A	6.0 kg	

912 Single-wire broadband dipole (2 - 30 MHz) - 150 W PEP

27 metres stainless steel and encapsulated baluns and loads.

Includes:-

- 30 metres of RG-58AU coaxial cable with waterproof UHF coaxial connectors

Note:- Masts illustrated not provided.

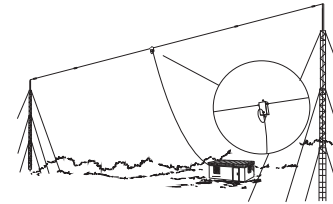

x	x	BC91201	N/A	3.6 kg	
---	---	---------	-----	--------	--

912 Multi-wire broadband dipole (2 - 30 MHz) - 500 W PEP

27 metres stainless steel, fibreglass spreaders and encapsulated baluns and loads.

Includes:-

- 30 metres of RG-213 coaxial cable with waterproof UHF coaxial connectors

Note:- Ground catenary and masts illustrated not provided.

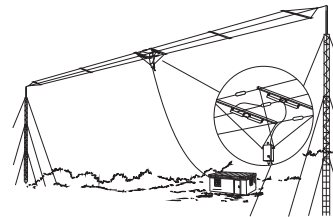

x	x	BC91202	N/A	15 kg	
---	---	---------	-----	-------	--

912 Multi-wire broadband dipole (3.6 - 30 MHz) - 1 kW continuous

27 metres stainless steel, fibreglass spreaders and encapsulated baluns and loads.

Includes:-

- 30 metres of RG-213 coaxial cable with waterproof UHF coaxial connectors

Note:- Ground catenary and masts illustrated not provided.

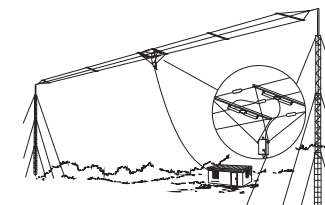

Option for		Part Number	Packaging Type	Net Weight	
2030	2050				
x	x	BC91203	N/A	15 kg	

912 Multi-wire broadband dipole (2 - 30 MHz) - 1 kW continuous

54 metres stainless steel, fibreglass spreaders and encapsulated baluns and loads.

Includes:-

- 30 metres of RG-213 coaxial cable with waterproof UHF coaxial connectors

Note:- Ground catenary and masts illustrated not provided.

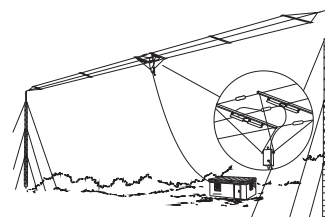

x	x	BC91207	N/A	25 kg	
---	---	---------	-----	-------	--

Halyard and pulley kit - to suit 912 Broadband antennas

Option for		Part Number	Packaging Type	Net Weight	
2030	2050				
x	x	BCA91201	C6	1.20 kg	

Includes:-

- 2 off stainless steel pulleys
- 100 metres of braided nylon halyard



NVIS kit - to suit BC91200 150 W PEP Multi-wire broadband dipole antenna

x	x	BCA91202	C4	0.40 kg	
---	---	----------	----	---------	--

Includes:-

- Stainless steel vertical feeder
- All fixing hardware
- Installation manual

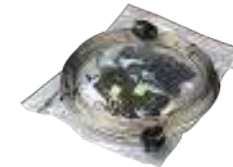
Note :- It does not suit 500 W or 1 kW broadband dipole antennas

Offset bracket and pulley

x	x	BCA90200	N/A	2.20 kg	
---	---	----------	-----	---------	--

To facilitate mounting of 912 Broadbands or 915 Wire dipoles in an inverted "V" configuration on either 902 Winch-up towers or 902 Telescopic masts.

Pulley to suit 4 mm halyard.



30 metres Coaxial cable RG-58

Option for		Part Number	Packaging Type	Net Weight	
2030	2050				
x	x	BCA90047	C6	1.20 kg	

30 metres of RG-58 coaxial cable with high quality "UHF" type connectors.

Coaxial cable RG-213 (per metre)

x	x	BCA90045	C4	0.15 kg	
---	---	----------	----	---------	--

High quality RG-213 coaxial cable.

Coaxial connector - UHF - Suit RG-213

x	x	BCA90046	C4	0.20 kg	
---	---	----------	----	---------	--

High quality waterproof "UHF" type coaxial connector - to suit RG-213 coaxial cable above.



Lightning arrestor 1S-50UX-CO

Option for		Part Number	Packaging Type	Net Weight	
2030	2050				
x	x	BCA90034	T1 & C6	2.05 kg	

Includes:-

- 1 x Surge arrestor with UHF (female) connectors
- 1 x 5 metres length of RG58 Coaxial cable with UHF (male)
- 1 x Steel dolly
- 1 x 3 metres earth braid
- 1 x Brass cable clamp assembly
- 1 x Copper plated steel earth rod

Lightning arrestor 1 Kw

x	x	BCA207503	T1 & C6	2.45 kg	
---	---	-----------	---------	---------	--

Includes:-

- 1 x Surge arrestor with UHF (female) connectors
- 1 x 5 metres length of RG213 Coaxial cable with UHF (male)
- 1 x Steel dolly
- 1 x 3 metres earth braid
- 1 x Brass cable clamp assembly
- 1 x Copper plated steel earth rod

Grounding kit

x	x	BCA90056	T1 & C6	1.85 kg	
---	---	----------	---------	---------	--

Includes:-

- 1 x Steel dolly
- 1 x 3 metres earth braid
- 1 x Brass cable clamp assembly
- 1 x Copper plated steel earth rod



**10 metres Lightweight, air transportable aluminium mast - nylon guys
 - ground mounting**

Option for		Part Number	Packaging Type	Net Weight	
2030	2050				
x	x	BC90205	N/A	27 kg	

Suitable for rapid deployment of Barrett 912 125 W PEP Broadband antennas or 915 Series wire dipoles. Packed length 2 metres, suitable for air-freight.

Includes:-

- Offset bracket and pulleys
- Nylon guys, guy anchor pegs, pulleys and halyard
- Installation instructions

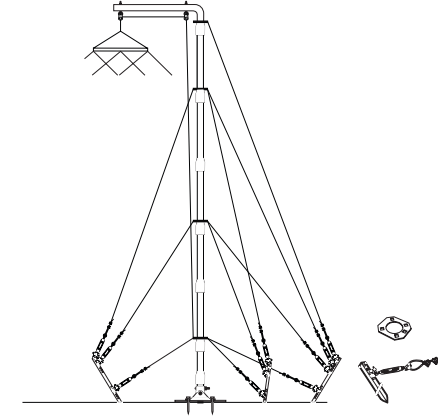

**10 metres Lightweight, air transportable aluminium mast - stainless steel guys
 - ground mounting**

x	x	BC90206	N/A	32 kg	
---	---	---------	-----	-------	--

Suitable for rapid deployment of Barrett 912 125 W Broadband antennas or 915 Series wire dipoles. Packed length 2 metres, suitable for air-freight.

Includes:-

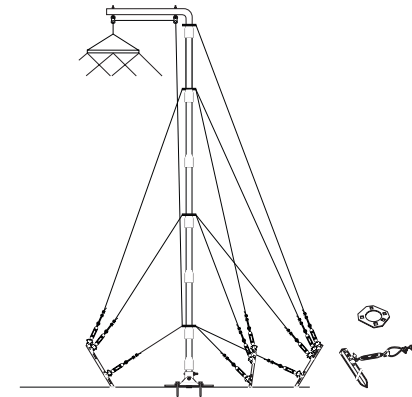
- Offset bracket and pulleys
- S/S guys, guy anchor pegs, pulleys and halyard
- Installation instructions



10 metres Lightweight, air transportable aluminium mast - stainless steel guys - roof mounting

Option for		Part Number	Packaging Type	Net Weight	
2030	2050				
x	x	BC90207	N/A	32 kg	

Suitable for rapid deployment of Barrett 912 125 W Broadband antennas or 915 Series wire dipoles. Packed length 2 metres, suitable for air-freight.

Includes:-

- Offset bracket and pulleys
- S/S guys, guy anchor brackets, pulleys and halyard
- Installation instructions.

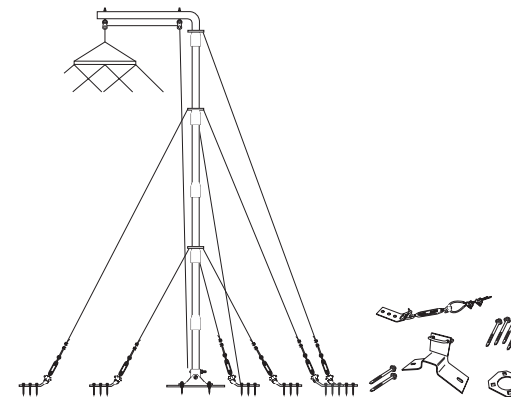

6 metres Lightweight, air transportable aluminium mast - nylon guys - ground mounting

x	x	BC90209	N/A	20 kg	
---	---	---------	-----	-------	--

Suitable for rapid deployment of Barrett 2017 Automatic Tuning Horizontal Dipole. Packed length 2 metres, suitable for air-freight.

Includes:-

- Nylon guys, guy anchor pegs and halyard
- Installation instructions

